



XYZ PRINTING

3D PRINTER

ENG

da Vinci nano



QUICK GUIDE

Thank you for purchasing da Vinci nano 3D printer. (Hereinafter referred to as da Vinci nano.) This product is a small and portable 3D printer, you can use da Vinci nano to take your imagination to a new level and bring any idea to life.

Before you start printing, please read this manual to learn how to use da Vinci nano correctly. This manual describes da Vinci nano safety instructions, operating instructions, maintenance information and application tips. For the latest information of da Vinci nano 3D printer, you can contact your local Authorized Distributors or refer to the official website of XYZprinting. (<http://www.xyzprinting.com>).

Table of Contents

2	Product Overview
3	Printer Setup
6	Software Setup
7	Software Functional Descriptions
9	Maintenance
10	Troubleshooting



XYZmaker is a software that is used to operate the da Vinci nano and prepare 3D models for printing. Download XYZmaker from <http://xyzptr.com/go2nano> and install it on your computer.

Note: First time installation requires an Internet connection.



HD23FNAX085

Product Overview

Product Details

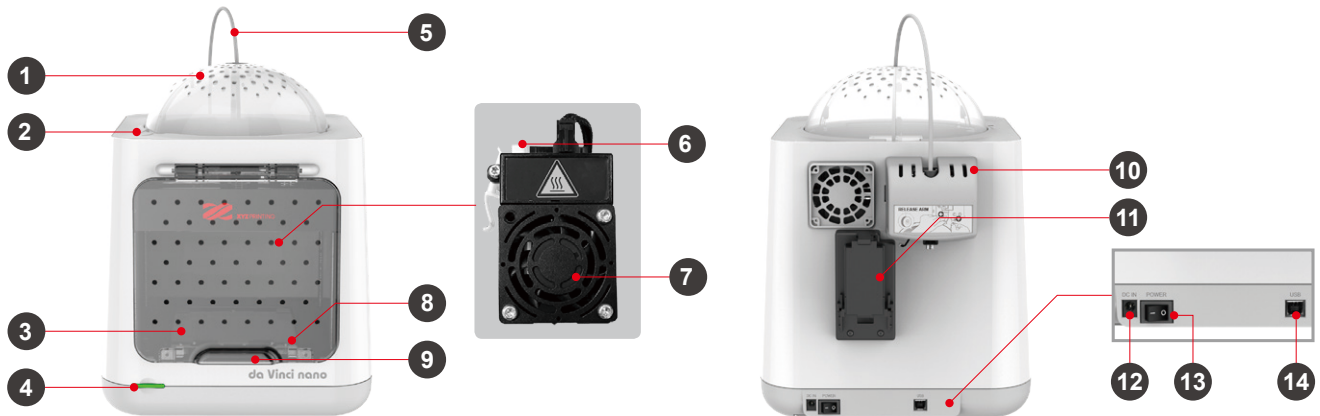

- | | | | |
|---|---------------------------|-----------------------|------------------|
| 1. Top cover | 5. Guide tube | 9. Front cover handle | 13. Power switch |
| 2. Top cover latch | 6. Detection head trigger | 10. Feed module | 14. USB port |
| 3. Print bed | 7. Extruder module | 11. Filament holder | |
| 4. Function button/
Status indicator | 8. Hold-open component | 12. Power socket | |

Specification

Print Technology	Fuse Filament Fabrication (FFF)	Weight	4.7kg
Dimensions	378*280*355 mm	Print Dimension	120*120*120 mm
Print Resolution	0.1-0.4 mm	Nozzle Diameter	0.4 mm
Print Material	PLA, Tough PLA, PETG	Filament Diameter	1.75 mm
Print Software	XYZmaker	File Format	.3w/ .stl/ .3mf
Operating System	Microsoft Windows 7 + Mac OSX 10.9 +	Connectivity	USB cord 2.0

Button and Indicator light

Indicator signals	Status	Action
Solid green	Standby/Ready to print	-
Flashing green	Receiving data	-
Solid red	General error	Press the button to return to printing status, refer to instructions in software to fix. *
Flashing red	Critical error	Refer to instructions in the software to solve the issue or reboot the nano. *
	Printing	-
Solid orange	Pause the print	To pause the print, press the button once.
	Cancel the print	To cancel the print, press and hold the button for 5 seconds.
Flashing orange	Paused	-
	Resume the print	To resume the print, press the button once.
Pulsing orange	Job complete (printing complete / printing cancellation complete)	To return to stand-by mode, press the button once.

*Please refer to "XYZmaker" software screen to solve the problem.

Printer Setup

Accessory Checklist



1. Quick Guide & Warranty Card

Printing Accessories

2. Scraper
3. USB Wire
4. Guide Tube
5. Bed Tape x 3
6. Power Adapter
7. Power Cord
8. Bundled Filament

Maintaining Accessories

9. Feeding Path Cleaning Pin
10. Nozzle Cleaning Wire x 5
11. Cleaning Brush
12. Feeder

Unpacking

Note

Keep original packaging materials in case you need to send your unit back for repair during the warranty period. If other packing materials are used instead, the printer may become damaged during transportation. In such a situation, XYZprinting reserves the right to charge a repair fee.

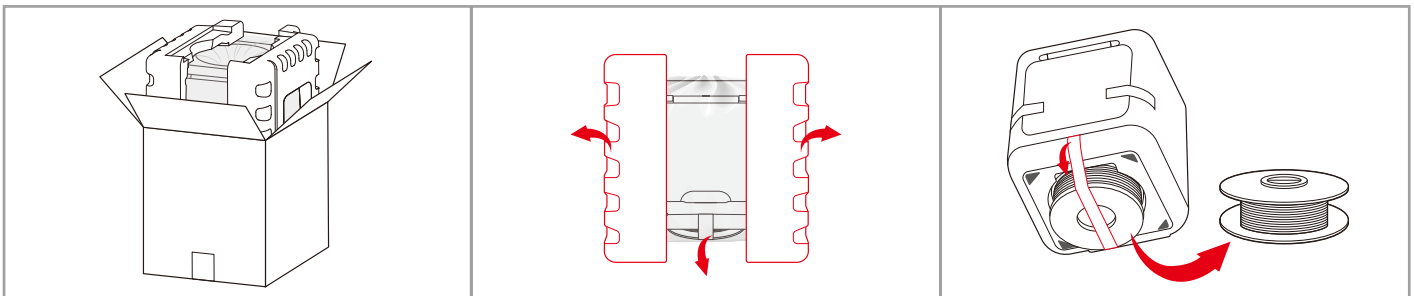

01 Take out the accessories, top cover and printer.

02 Remove the styrofoam packing material on sides and the plastic bag.

03 Remove the fixed tape from the printer bottom and take out the filament.

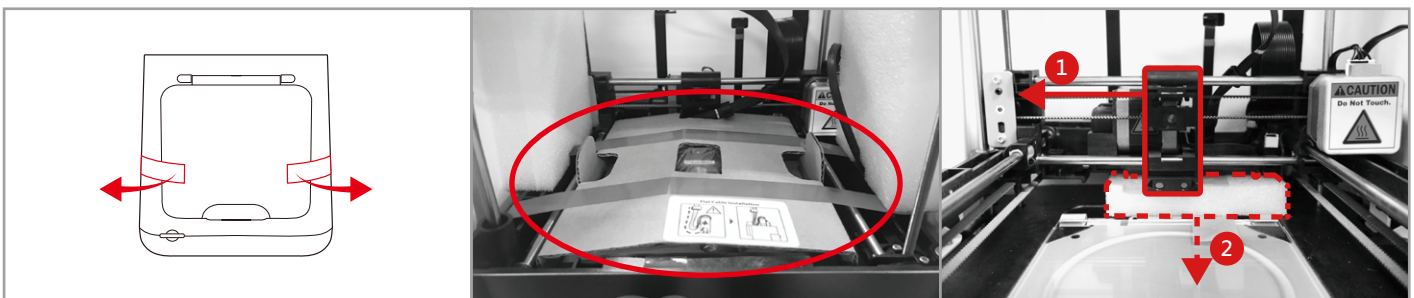

04 Remove the fixed tape on front cover sides.

05 Remove the fixed tape on the extruder module and print bed packaging.

06 Please remove all fixed materials before turning on the printer to prevent the machine from damage.



07 Remove the fixed tape on the extruder module and print bed packaging.

Printer Setup



WARNING: Hazardous Moving Parts. Keep Fingers and Other Body Parts Away.

AVERTISSEMENT: Dangereux Les Parties Mobiles. Evitez tout contact avec les doigts et toute autre partie du corps.

Install the Guide Tube and Extruder Module

This equipment must be grounded. The power cord for product should connect to a socket-outlet with earthing connection.

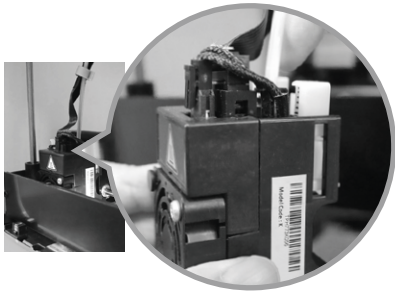

01 Insert guide tube into the extruder module port.

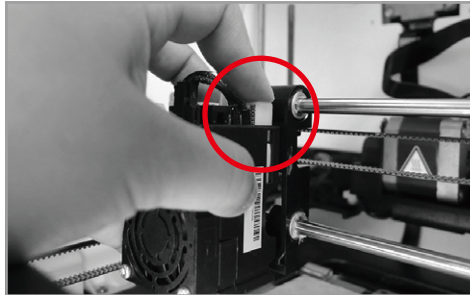

02 Press the white button and align the extruder module with the bracket. Once aligned, release the white button to connect the extruder module with the bracket.

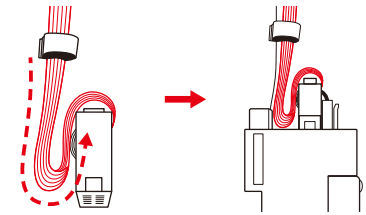

03 Follow the illustration to bend the flat cable.

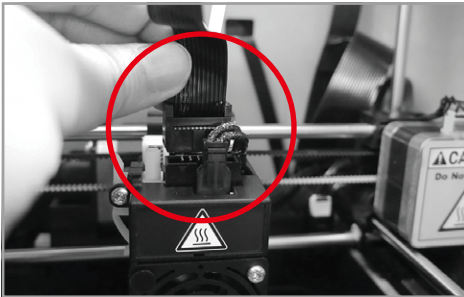

04 Connect the flat cable to the extruder module. (Be sure to insert the flat cable in the right direction.)

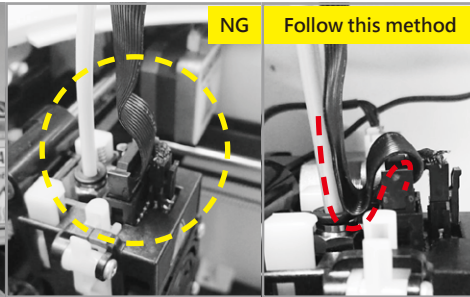

05 The flat cable is bending for printing smoothly purpose, please do not adjust.

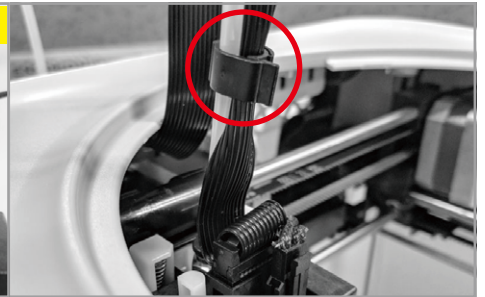

06 Use the cramp ring to hold the filament guide tube and flat cable. (Place the cramp ring on the flat cable marker.)

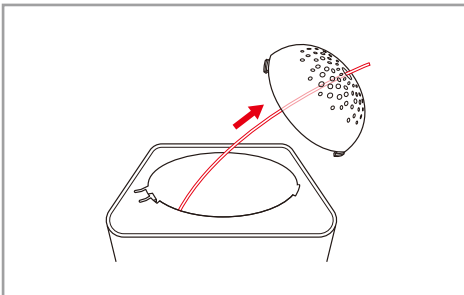

07 Feed the guide tube through the top cover.

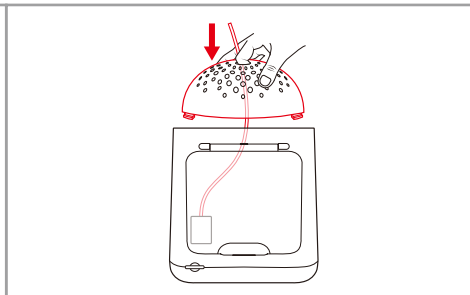

08 Attach the top cover to the machine.

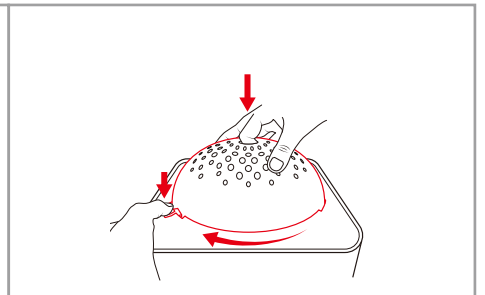

09 Direct the bottom locking catches toward their slots then press the latch to rotate clockwise.

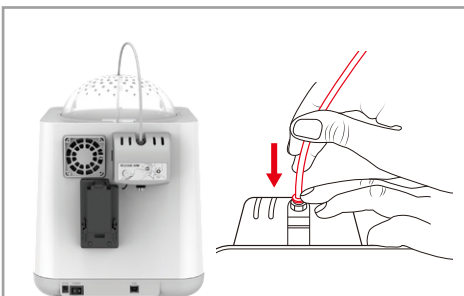

10 Ensure that the guide tube has been tightly inserted into the feed module port.



Note

To load the filament, refer to the [Software Setup] section.

Printer Setup

Installing the Filament

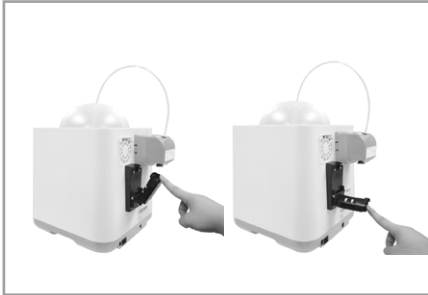

01 Lower the filament spool holder on the back side of the printer until horizontal.

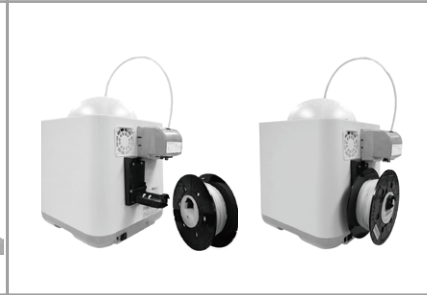

02 Place the assembled filament spool (with the spool ring) on the spool holder.

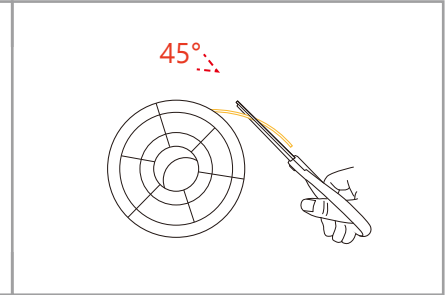

03 The filament will load better when the tip of the filament is cut at a 45° angle.

Remove Print Bed



04 Open the hold-open component and take out the print bed.

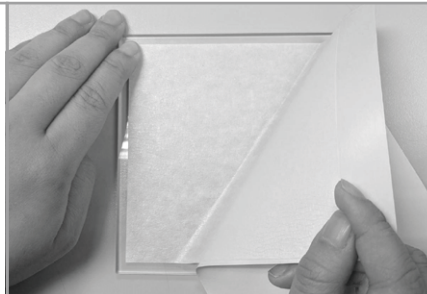

05 Stick the bed tape onto the print bed. (align center)

Note: The bed tape is reusable, and only needs to be replaced when it is worn out.

Note

- The filament will load better when the tip of the filament is cut at a 45° angle.
- When the printer is not in use, raise the filament spool.
- If the room temperature is below 25°C / 77° F, apply some glue to the bed tape for better part adhesion.

Software Setup



XYZmaker is a software that is used to operate the da Vinci nano and prepare 3D models for printing. Download XYZmaker from <http://xyzptr.com/go2nano> and install it on your computer. First time installation requires an Internet connection.

Load Filament

- 01** Open up XYZmaker and click [File] > [Print] > [da Vinci Printer Plugin]. This will display a print screen that lets you set print settings and prepare your printer.

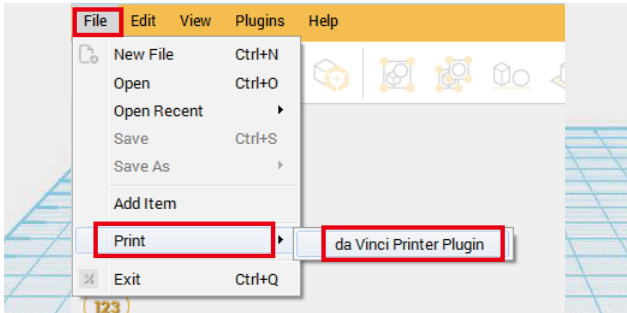

- 02** Click [DASHBOARD] then click [Filament] > [Load Filament].

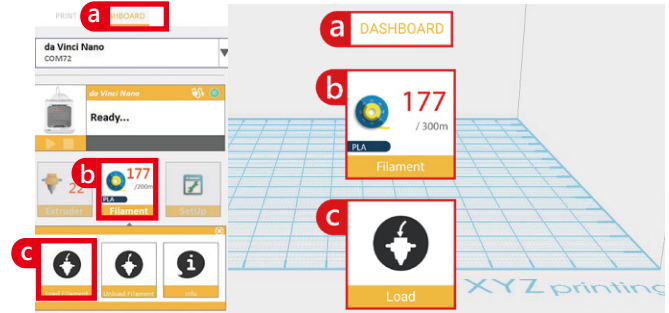

- 03** Follow the on-screen instructions to install the filament. **04** Take the tip of the filament and insert it into the feeding hole. The printer will start to load the filament automatically.

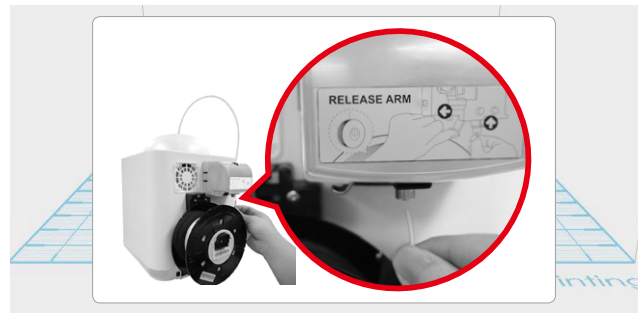
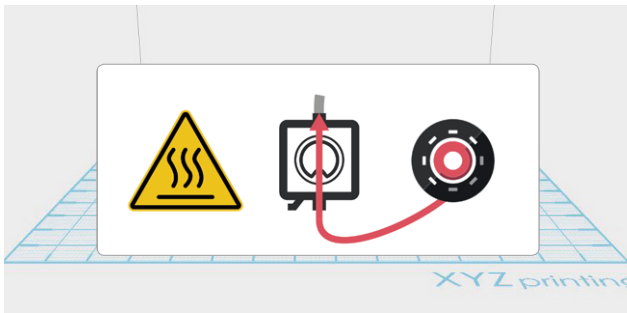

- 05** When the print head extrude filament, you can click [FINISH] to complete the step of loading filament.

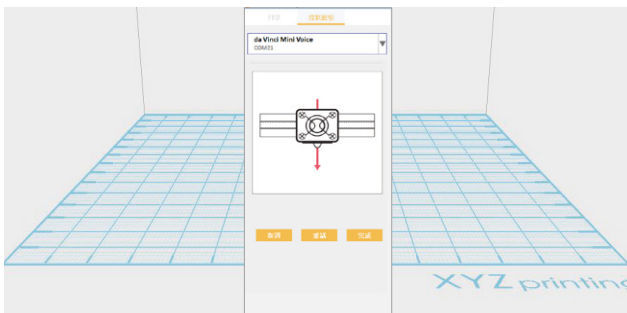

Hot parts! Burned fingers when handling the parts. **Do Not Touch.**

Parties Chaudes! Brûler les doigts lorsque de la manipulation des composants. **Ne pas toucher.**

Software Setup

Printing

* For better printing results, we recommend that you calibrate before printing.

- 01 Click [File] > [Open]. Import your favorite 3D files. Click on the object to adjust the size you need.

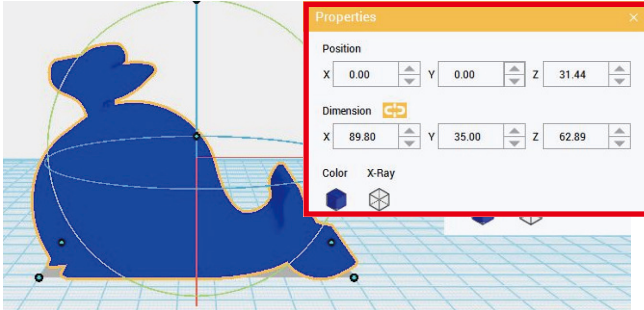

- 02 When the object is adjusted, you can start printing. Click [File] > [Print] > [da Vinci Printer Plugin].

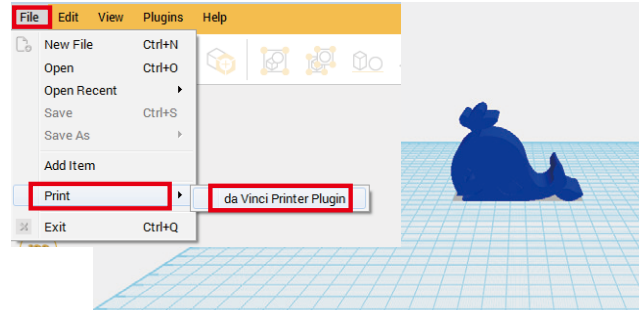

- 03 When you're done adjusting the print parameters you need, click [PREPARE].

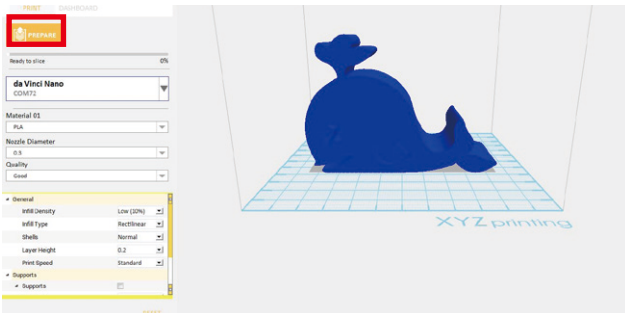

- 04 After preparing, please check if the object is a complete model. After the confirmation, click [PRINT].

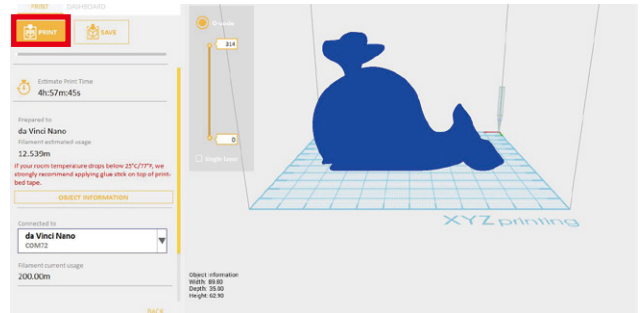

- 05 When the print job begins, the printer will print a line on the print bed to ensure the filament is extruding properly.

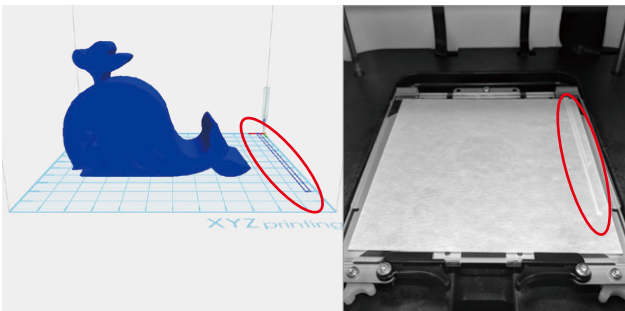

Check List

- Setup your 3D printer
- Download XYZmaker
- Load Filament
- Try to print a sample

Start to Create!

Note

- When the printer starts printing, you can monitor the status by clicking [DASHBOARD].
- The recommended operating temperature is 15°C ~ 32°C (59 °F ~ 90 °F). If the room temperature is above this, please open the front cover to maintain print quality.
- After the print is finished, the object may be removed with a scraper.
- When using different types of filament, we recommend changing the extruder module.

Software Functional Descriptions

Interface Introduction

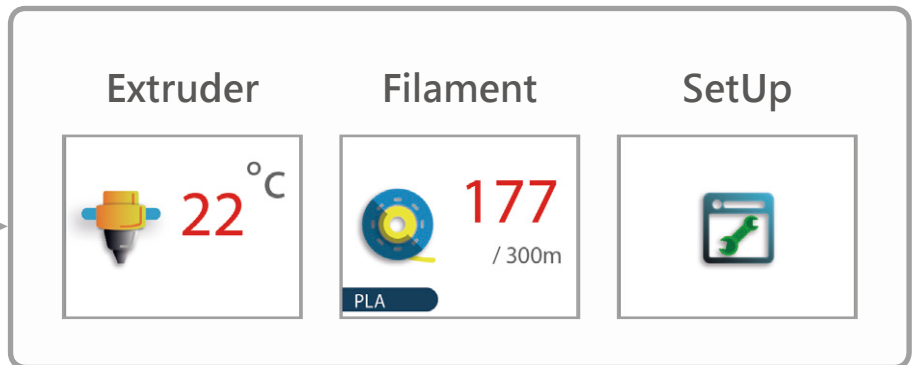
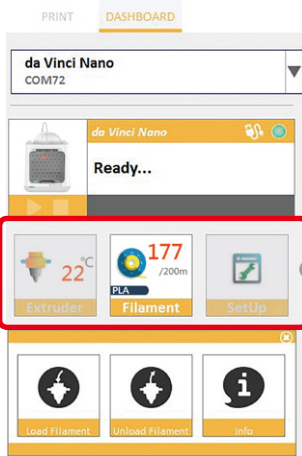

Extruder



Clean Nozzle

Once this function is selected, the nozzle will heat up automatically and move the nozzle to a proper location where you can easily clear away all residual plastic on the nozzle.



Info

The extruder module information, including Temperature, Nozzle Diameter, Total Print Time, and Serial Number.



Load Filament

Please follow the on-screen instructions.

The extruder module will automatically move to the working position. The nozzle will then heat up and begin the filament loading process. After this is complete, verify that plastic has been extruded. If not, please repeat the filament loading process.



Unload Filament

Please follow the on-screen instructions.

The printing module will automatically move to the working position. The nozzle will then heat up and begin the filament unloading process.



Info

Information related to filament use.

Software Functional Descriptions

Interface Introduction

SetUp

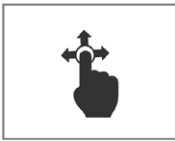

Jog Mode

Manually adjust the movement of X/Y/Z Axis for printer maintenance.

Note

1. First click on **Home Axes**. The extruder module will be returned to the initial axis position.
2. You may manually enter the adjustment value:
Range: 1 to 150; step: 1 mm

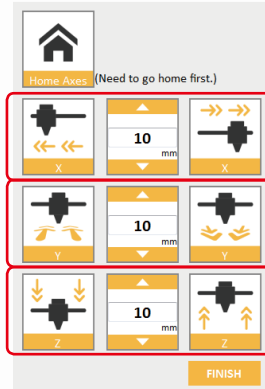

Move extruder module rightwards and leftwards.

Move extruder module forwards and backwards.

Move the print axis (Z-AXIS) upwards and downwards.

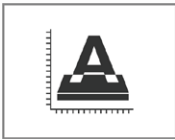

Calibrate

Before starting the calibrate function, please press the white detection head trigger button.

Please follow the on-screen instructions. Print bed calibration may be implemented before the printing process. Move the extruder module to the lower left corner of the printing area. Please refer to the calibrate instructions provided by the software.

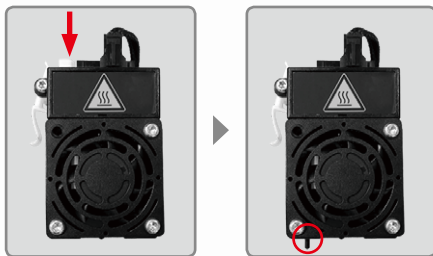

Z-Offset

Z-Offset function will help you to adjust the printing distance between the print bed and extruder module.

Each adjustment has a step of 0.05 mm.

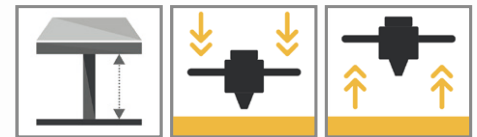

Others

Automatic horizontal calibration

Automatic horizontal calibration may either be ON or OFF. Default: ON.

The printer would automatically implement horizontal calibration and compensation accordingly. Printing speed will be improved if automatic horizontal calibration has been switched to OFF. However, this may affect printing quality.

Buzzer

Buzzer may either be ON or OFF. Default: ON.

When the buzzer is turned on, the printer will output an audible signal when a button is pressed, receiving data, print job is finished, or issue is detected.

Restore Default

Click **Restore Default** to reset to default setting.



FW upgrade

Please upgrade the latest firmware version for the best printing quality of the printer.



Info

Information related to printer setting.

Maintenance

Z-offset

When the printing module has been moved, we recommend that you use z-offset. This function will help you to adjust the printing distance between the print bed and the extruder module.

- Step**
1. Please unload the filament and clean the nozzle before using z-offset.
 2. Click [DASHBOARD] > [SetUp] > [Z offset] to start z-offset adjustment.
 3. Adjust Z up or Z down to find the proper distance.

- Note**
- This product is factory tested and adjusted, we suggest you note the default value for z-offset before your adjustment.
 - Suggested distance between nozzle and print bed(including bed tape) is 0.3mm.

Clean the nozzle

In order to maintain a good printing quality, it is recommended that you clean the nozzle after every 25 hours of printing. Please use the **Clean Nozzle** function in the software.

- Step**
1. Switch on the power and click [DASHBOARD] > [Extruder] > [Clean Nozzle].

2. Please clamp the nozzle cleaning wire with needle-nosed pliers to insert it into the head of the nozzle carefully for cleaning.

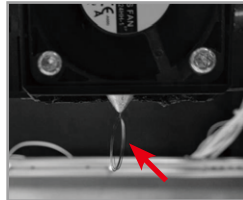

3. Lightly press the spring around the feed hole and remove the filament guide tube (don't need to remove the heating cable at the side)

4. Insert the Feeding Path Cleaning Pin into the feeding path all the way down and "floss" the inside of the nozzle to pull the residue out.

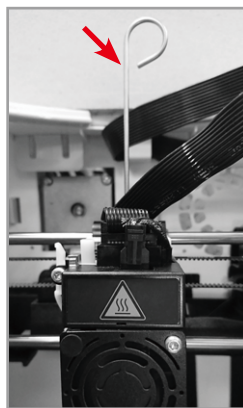

5. After cleaning the feeding path, reinstall the filament guide tube and extruder module.

Tool Nozzle Cleaning Wire 

Feeding Path Cleaning Pin 

Print bed calibration

Print bed level will affect the 3D printing quality, XYZprinting's 3D Printer has been adjusted to the best condition before leaving the factory. After long periods of use, the print bed level may change. If you have print adhesion problems, you may need to re-level the print bed.

- Step**
1. Switch on the power and activate the **Calibrate** function in XYZmaker.
 2. Please follow the on-screen instructions.

Clean the filament feed module

After long periods of use, the automatic feed system may inconsistently extrude filament, due to a buildup of residual plastic in the feed module. The printer filament feed module should be cleaned if this happens or after cleaning the nozzle.

- Step**
1. Open the feed module cover.
 2. Clean the gears by using a gear cleaning brush.

Tool Cleaning Brush 

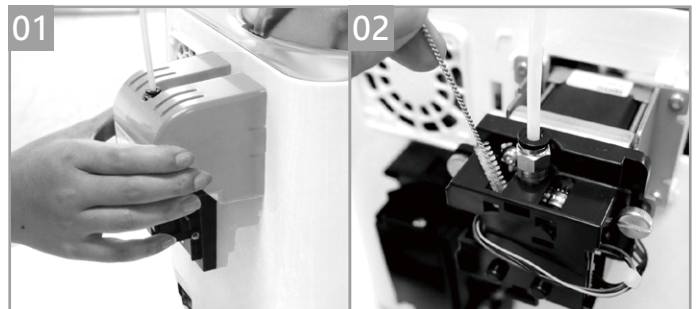

Please switch off the power before cleaning the filament feed module.

How to Remove the Guide Tube

- Step**
1. Use two fingers press the Feeder on the Feed module.
 2. Pull out the guide tube.

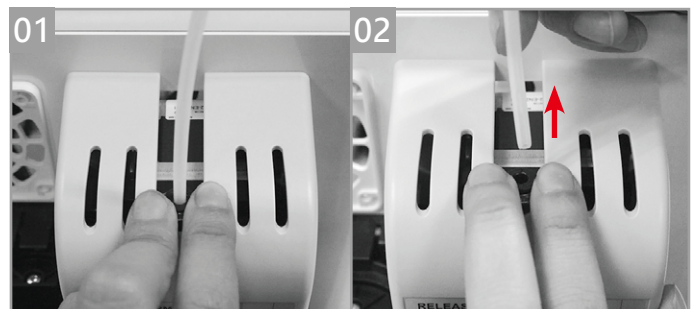

Maintenance

Replace the New Filament Spool

*If you have just unboxed the da Vinci nano, the sensor chip should already be loaded.

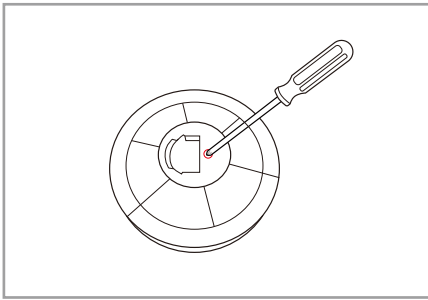

01 Use a Phillips head screwdriver to loosen the securing screws of the filament spool ring.

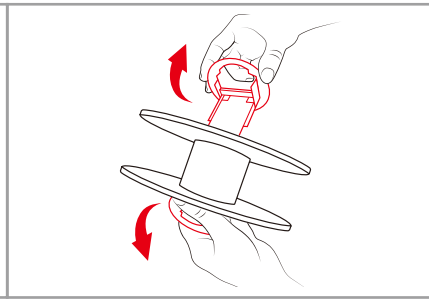

02 Separate the spool ring from both sides of the spool.

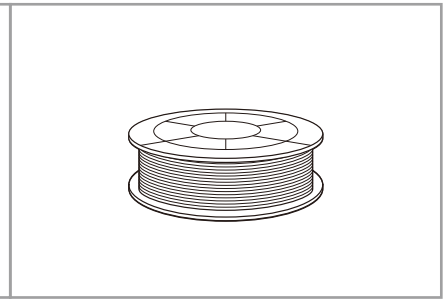

03 Take out the filament spool and the sensor chip.

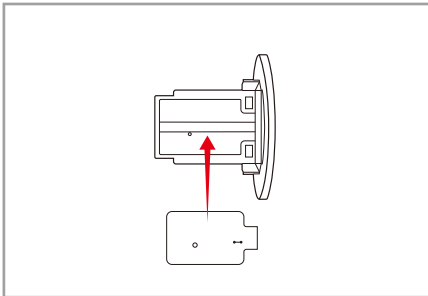

04 Install the sensor chip. Note the orientation of the sensor chip on the spool ring.

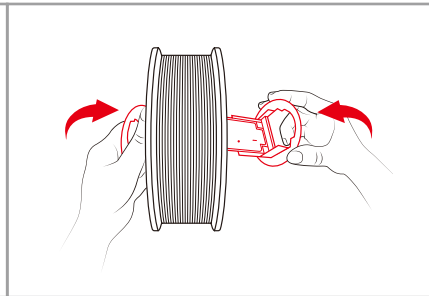

05 Feed both parts of the spool ring through the center hole of the spool and assemble them together.

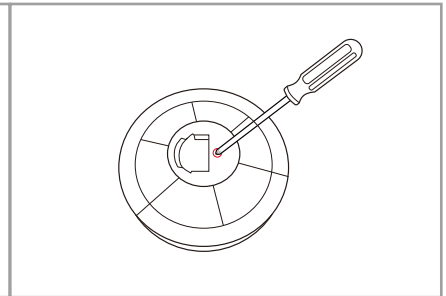

06 Use a Phillips head screwdriver to tighten and secure the spool ring to complete the installation.

Troubleshooting

Error Code No.	Software interface	Action
E2	Updating Firmware for printer. Do not power off your printer now!	Wait for the update completed, it will resume to READY status.
0007 0008	Spool 1 Error. Please remove spool and install again. If errors persists, please contact service center for support.	Reinstall or replace the filament cartridge.
0011 0014	Heating Error. Please turn off the printer and contact service center for support.	Check whether the connections are connected properly and restart as required.
0016	Spool 1 not installed properly. Please reinstall spool 1 ([Unload Filament] then [Load Filament]) on your printer. If error persists, please contact service center for further support.	Reinstall the filament cartridge.
0028	Spool 1 can not be found. Please install one.	Reload or replace the filament.
0029	There is no filament left in spool 1. Please replace spool 1 before printing.	Replace filament immediately.
0030	Printer motor Error(X-Axis). If error persists, please contact service center for support.	
0031	Printer motor Error(Y-Axis). If error persists, please contact service center for support.	Check motor/sensor connections. Check sensor position.
0032	Printer motor Error(Z-Axis). If errors exist, please contact service center for support.	
0050	Memory error, please contact service center for support.	Reboot the printer.
0051	Flash ram cannot be read/written.	
0052	Memory in the extruder cannot be read/written.	Replace the nozzle.
2001	Computer and printer connection issues.	Re-connect the computer with the printer. Alternatively, you may use hot plugging of the USB cable to connect the computer with the printer.